

Name \_\_\_\_\_

# Minnesota Comprehensive Assessments-Series II

Mathematics Item Sampler  
Grade 11





# GRADE 11 FORMULA SHEET

You may use the following formulas to solve problems on this test.

## Area of a Square

$$A = s^2$$



## Area of a Rectangle or a Parallelogram

$$A = bh$$

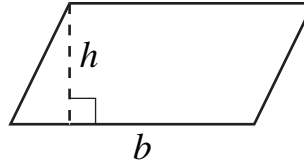
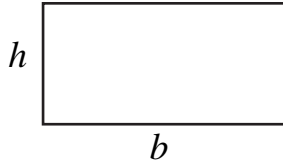

## Area of a Triangle

$$A = \frac{1}{2}bh$$

$$A = \frac{1}{2}ab \sin \theta$$

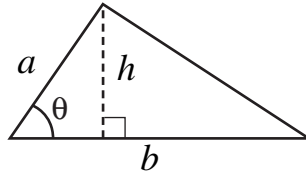

## Area of a Rhombus or a Kite

$$A = \frac{1}{2}d_1d_2$$

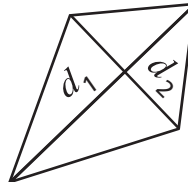
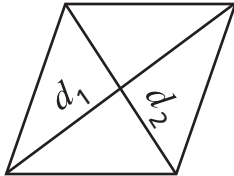

## Area of a Trapezoid

$$A = \frac{1}{2}h(b_1 + b_2)$$

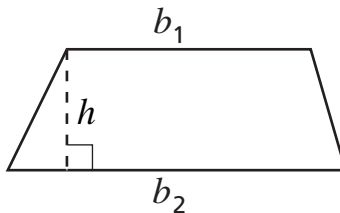

## Area of a Regular Polygon

$$A = \frac{1}{2}Pa$$

where  $P$  is the perimeter and  $a$  is the apothem.

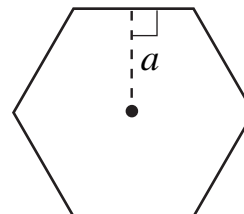

## Area of a Circle and Circumference of a Circle

$$A = \pi r^2$$

$$C = 2\pi r$$

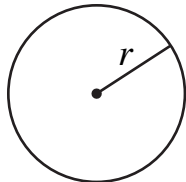

## Length of an Arc of a Circle and Area of a Sector of a Circle

$$s = \frac{m}{360} C$$

$$A_{\text{sector}} = \frac{m}{360} A_{\text{circle}}$$

$m = \text{degrees}$

$$s = r\theta$$

$$A = \frac{1}{2} r^2 \theta$$

$\theta = \text{radians}$

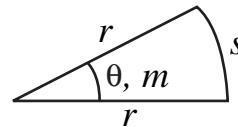

## Volume of a Prism or a Cylinder

$$V = Bh$$

where  $B$  is the area of the base

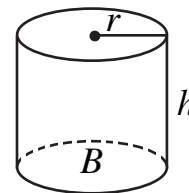
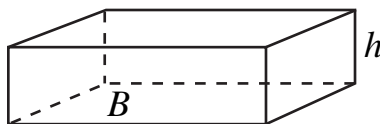

## Volume of a Pyramid or a Cone

$$V = \frac{1}{3} Bh$$

where  $B$  is the area of the base

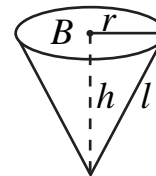
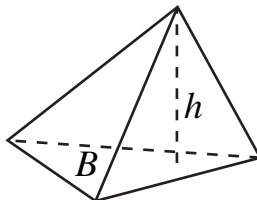

## Volume of a Sphere

$$V = \frac{4}{3} \pi r^3$$

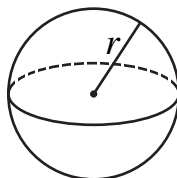

### Pythagorean Theorem

$$a^2 + b^2 = c^2$$

### Distance Formula

$$d = \sqrt{(x_2 - x_1)^2 + (y_2 - y_1)^2}$$

### Quadratic Formula

$$x = \frac{-b \pm \sqrt{b^2 - 4ac}}{2a}$$

### Direct Variation

$$y = kx$$

### Indirect Variation

$$y = \frac{k}{x}$$

### Combination of $n$ Things Taken $r$ at a Time

$${}^n C_r = \binom{n}{r} = \frac{n(n-1)(n-2)\dots}{r!(n-r)!} = \frac{n!}{r!(n-r)!}$$

### Permutation of $n$ Things Taken $r$ at a Time

$${}^n P_r = \frac{n!}{(n-r)!}$$

### Special Triangles

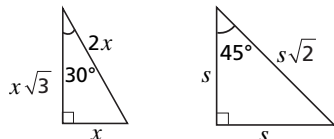

### Trigonometric Relations

$$\sin \theta = \frac{\text{opposite}}{\text{hypotenuse}}$$

$$\cos \theta = \frac{\text{adjacent}}{\text{hypotenuse}}$$

$$\tan \theta = \frac{\text{opposite}}{\text{adjacent}}, \tan \theta = \frac{\sin \theta}{\cos \theta}$$

$$\sin^2 \theta + \cos^2 \theta = 1$$

## Mathematics Test General Directions to the Student

- This test contains four segments. Your teacher will tell you when to begin each segment.
- Your answers must be marked in your answer document, but you may write in this test book as scratch paper. Grid paper is provided at the back of the test book.
- A tear-off formula sheet is provided on pages 3–4.
- For each question, choose the answer you think is best. Answer each question by filling in the circle in your answer document. Each circle must be filled in completely for your answer to be scored.
- The sample questions show examples of questions that will be on the test. The sample questions show the answers filled in correctly.

**Sample Question:**  $20 - 8 =$

A. 8  
B. 10  
C. 12  
D. 16

**Sample Answer:** (A) (B)  (D)

**Sample Question:**  $4 - 12 =$

**Sample Answer:**

-	8				
●		7	7	7	
•	•	•	•	•	
0	0	0	0	0	
1	1	1	1	1	
2	2	2	2	2	
3	3	3	3	3	
4	4	4	4	4	
5	5	5	5	5	
6	6	6	6	6	
7	7	7	7	7	
●	8	8	8	8	
9	9	9	9	9	

- You **may** use a calculator for all segments.
- When you finish a segment of the test, stop and check your answers. Then use the sticker your teacher gives you to seal it. Once you seal a segment, you cannot go back to it. Each segment must be sealed before you move on to the next segment.

**MATHEMATICS ITEM SAMPLER**  
 Directions listed here reflect the actual test.  
 This Item Sampler may be reproduced.





## Segment 1

Your teacher will tell you when to begin this segment.

You **MAY** use a calculator for this segment.



# Mathematics Test — Segment 1

1

1. In 1977, there were 12,168,450 U.S. households with cable television. In 1997, there were 65,929,420 U.S. households with cable television. Over that time period, what was the average rate of change per year in households with cable television?
- A. 2,688,048.5 households/year
  - B. 5,376,097.0 households/year
  - C. 53,760,970.0 households/year
  - D. 65,320,997.5 households/year

Please fill in the grid with your answer to question 2 on page 2 of your answer book.

2. Harrison High School has 768 students. In 6 years, it is projected to have 1,157 students. What is the projected average rate of change per year in students over this time period? Round your answer to the nearest student.



3. A rabbit population grew in the following pattern: 2, 4, 8, 16, . . . If all the rabbits live and the pattern continues, how many rabbits will be in the 8th generation?

- A. 32
- B. 128
- C. 256
- D. 512

4. Pedro throws a ball upward at a rate of 20 meters per second from an initial height of 2 meters. The height of the ball above the ground can be approximated by  $h = -5t^2 + 20t + 2$ , where  $t$  represents the amount of time, in seconds, since the ball has been released.

What is the maximum height that the ball reaches?

- A. 5 meters
- B. 6 meters
- C. 20 meters
- D. 22 meters

5. Which graph shows a function?

A.

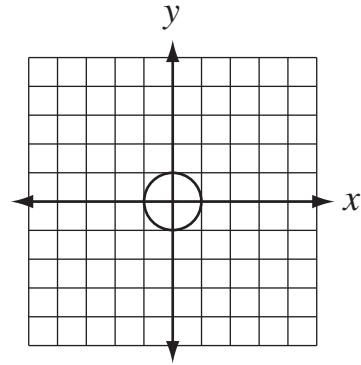

B.

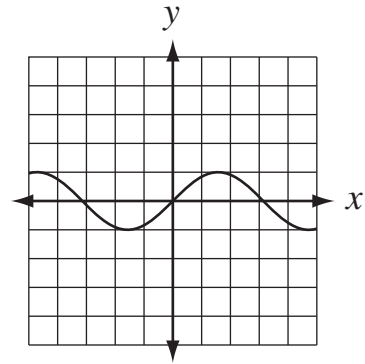

C.

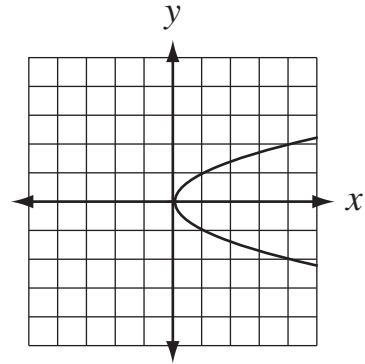

D.

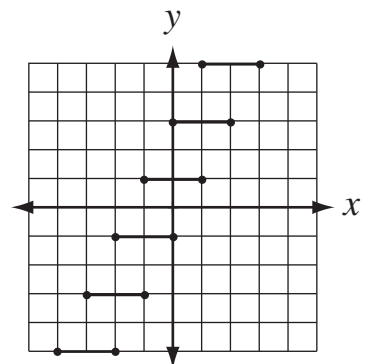

6. How can the following compound statement be combined into a statement using absolute value?

$$x < 5 \text{ and } x > -1$$

- A.  $|x+1| < 5$
- B.  $|x-5| < 1$
- C.  $|x-2| < 3$
- D.  $|x-3| < 2$

7. Tickets for a concert cost \$15.00 each plus \$1.50 each for handling charges. The shipping fee for an order of any number of tickets is \$4.00. Which equation could be used to determine the cost,  $C$ , of any number of tickets,  $t$ ?

- A.  $C = 15.00t + 5.50$
- B.  $C = 16.50t + 4.00$
- C.  $C = 17.00t$
- D.  $C = 20.50t$

8. Yia wrote the equation  $P = 0.25n - (0.05n + 1)$  to represent the school store's weekly profit,  $P$ , from sales of  $n$  pencils. Which equation is equivalent to Yia's equation?

- A.  $P = 0.20n - 1$
- B.  $P = 0.20n + 1$
- C.  $P = 0.125n^2 - 1$
- D.  $P = 0.0125n^2 + 1$

9. In an electric circuit, the power dissipated in a load can be modeled by the equation  $p = iv - i^2r$ . The following chart tells what each variable in the equation represents. In a certain circuit, the voltage supplied is 100 volts and the resistance of the rest of the circuit is 25 ohms. Which of the following currents can be present if the load is expected to use 75 watts of power?

$p$ = power used by a load in watts
$v$ = voltage supplied in volts
$r$ = resistance of the circuit external to the load in ohms
$i$ = current in the circuit in amperes

- A. 3 amperes
- B. 5 amperes
- C. 8 amperes
- D. 10 amperes

Use the diagram below to answer question 10.

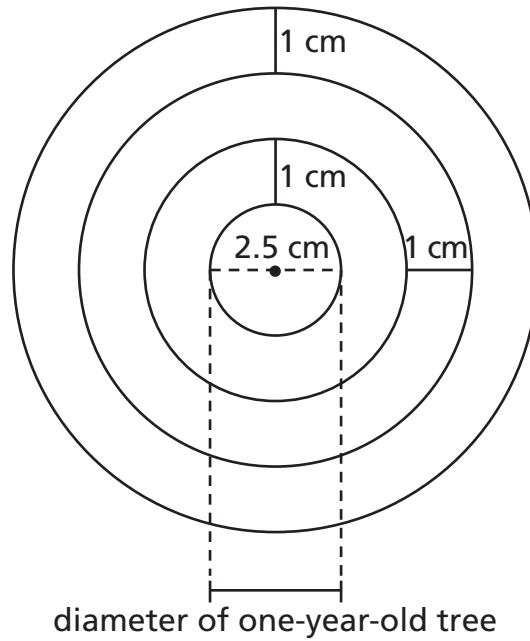

10. The yearly growth of a tree is modeled by concentric circles in a cross-sectional cut through the tree trunk as shown. The one-year-old tree has a diameter of 2.5 centimeters. Which equation models the diameter of the tree,  $d$ , in terms of the age of the tree in years,  $n$ ?
- A.  $d = 2.5n + 1$
  - B.  $d = 2.5n + 2$
  - C.  $d = 2.5 + 2n$
  - D.  $d = 2.5 + 2(n - 1)$

11. Two numbers are written in scientific notation as follows:  $7.3 \times 10^n$  and  $1.2 \times 10^q$ . What is the product of the two numbers?
- A.  $7.3 \times 1.2 \times 10^{n+q}$   
B.  $7.3 \times 1.2 \times 100^{n+q}$   
C.  $7.3 \times 1.2 \times 10^{nq}$   
D.  $7.3 \times 1.2 \times 100^{nq}$
12. Rosa wants to use \$20 to buy games. The inequality  $2.50k + 5.50 \leq 20.00$  represents the number of games,  $k$ , she can buy with her money. What is the greatest number of games Rosa can buy?
- A. 5  
B. 6  
C. 8  
D. 10

**This is the end of Segment 1.**

Check your work, then  
**SEAL** Segment 1.



Put sticker  
here

## Segment 2

Your teacher will tell you when to begin this segment.

You **MAY** use a calculator for this segment.



## Mathematics Test — Segment 2

13. The braking distance of Samir's car can be described by the equation:

$$y = \frac{x^2 + 5x}{200}$$

where  $x$  is the car's speed in kilometers per hour and  $y$  is the braking distance in meters.

How fast is the car traveling when the braking distance is 75 meters?

- A. 30 kilometers per hour
- B. 50 kilometers per hour
- C. 55 kilometers per hour
- D. 120 kilometers per hour

14. Given  $a_1 = 1$  and  $a_n = a_{n-1} + 2$ . Find  $a_7$ .

- A. 7
- B. 9
- C. 11
- D. 13

15. Dr. Franklin begins an experiment with 100 bacteria in a container. She finds that the number of bacteria present at any given time is modeled by the following recursive formula:

$$\begin{cases} a_0 = 100 \\ a_n = 2a_{n-1} \end{cases}$$

where  $n$  is the number of hours after the beginning of the experiment.

How many bacteria are present 5 hours after the beginning of the experiment?

- A. 1,000
- B. 1,600
- C. 3,200
- D. 6,400



Use the graph below to answer question 16.

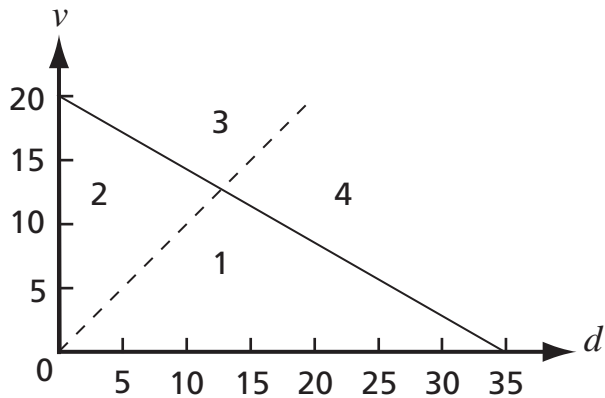

16. All of Tyler's DVDs and videotapes are on a shelf. The inequality  $d + 1.7v \leq 34$  represents the number of DVDs,  $d$ , and videotapes,  $v$ , that the shelf can hold. He owns fewer videotapes than DVDs, represented by the inequality  $v < d$ . The possible combinations of Tyler's DVDs and videotapes that the shelf can hold are found in which region of the graph?

- A. 1
- B. 2
- C. 3
- D. 4

Use the graph below to answer question 17.

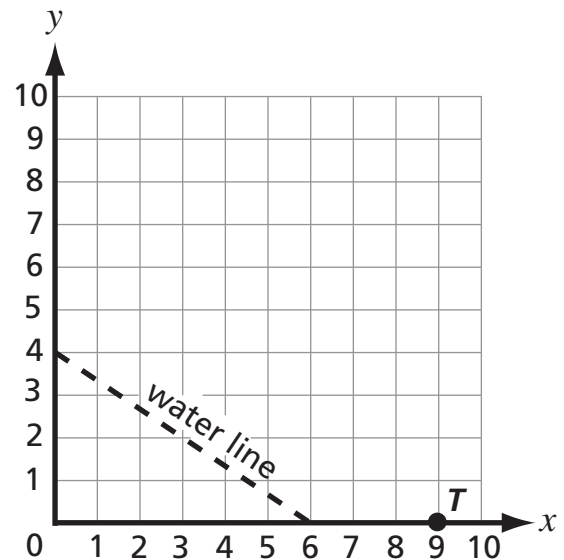

17. A contractor wants to lay an underground telephone cable across a field starting at the telephone pole,  $T$ . The cable should run parallel to the water line. Which of these is an equation for the line that the telephone cable should lie on?

- A.  $y = \frac{3}{2}x - 13.5$
- B.  $y = -\frac{4}{9}x + 4$
- C.  $y = -\frac{2}{3}x + 4$
- D.  $y = -\frac{2}{3}x + 6$

18. The heights, in inches, of the 15 students in Jared's grade 11 science class are 60, 66, 65, 74, 68, 67, 70, 65, 67, 69, 71, 68, 67, 70, and 68. What is the upper quartile,  $Q_3$ , of these data?

- A. 67
- B. 68
- C. 69
- D. 70

Use the table below to answer question 19.

**Number of Student Car Accidents  
in the School Parking Lot  
by Month**

Month	Number of Accidents
September	2
October	3
November	5
December	7
January	8
February	4

19. What conclusion can be made from the above data on six months of accidents?
- A. The median number of accidents is 6.
  - B. On average, more accidents happened in September and October than in January and February.
  - C. On average, more accidents happened in December, January, and February than in September, October, and November.
  - D. More students drive to school as the school year goes on.

Use the graph below to answer question 20.

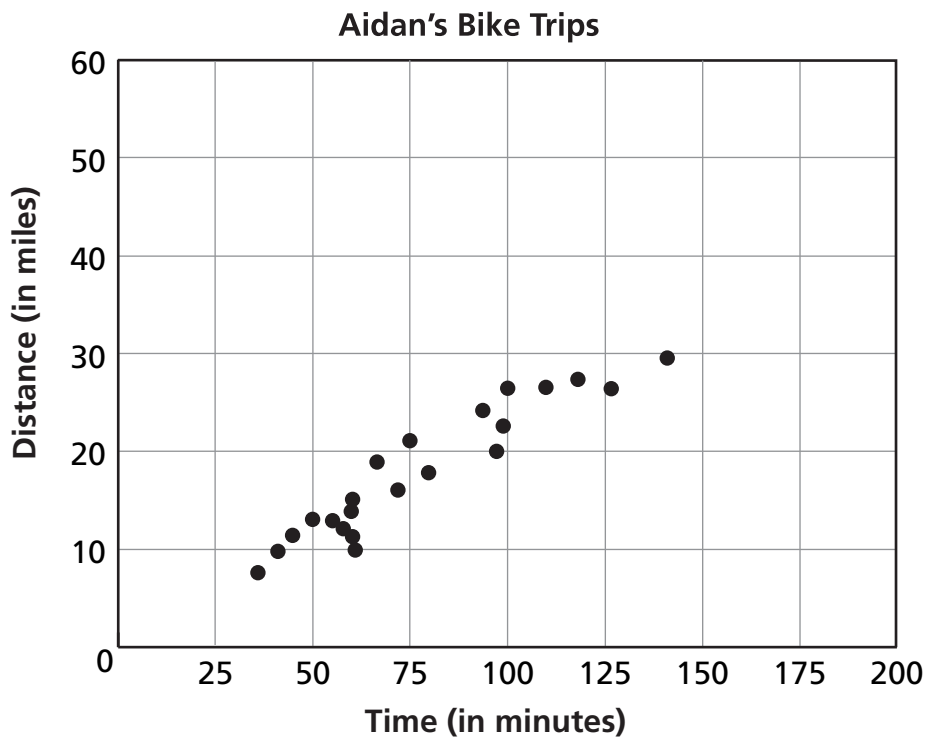

20. The scatterplot shows the time and distance that Aidan rode his bike on several trips. Using the scatterplot and assuming a linear relationship, about how many miles would Aidan travel if he rode for 175 minutes?
- A. 20 miles
  - B. 30 miles
  - C. 40 miles
  - D. 50 miles

Use the chart below to answer question 21.

**Hours of Sleep and Grade Point Average (G.P.A.)**

Student	Hours of Sleep per Night	G.P.A.
Alberto	7.2	3.5
Bao	4.3	2.1
Chris	5.5	2.6
Kim	5.1	2.5
Mona	6.2	3.0
Sandy	7.2	3.6
Yang	7.0	3.4

21. Which of the following statements is supported by the data?
- A. More sleep causes a person to have a higher G.P.A.
  - B. A higher G.P.A. allows a person to get more sleep.
  - C. In the sample study, sleep and G.P.A. are positively correlated.
  - D. Schoolwide, sleep and G.P.A. are positively correlated.

Use the graph below to answer question 22.

**Turkeys Raised in 2001**

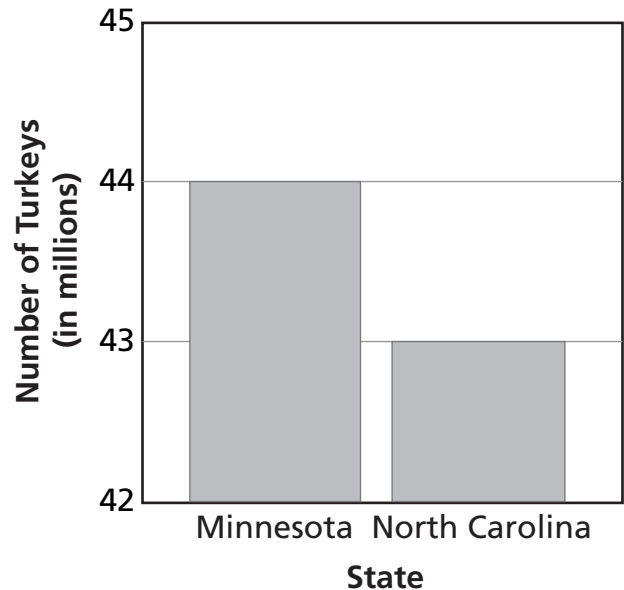

22. Dave drew this graph to give the impression that Minnesota raised a much greater number of turkeys than North Carolina. To the nearest percentage, what is the percentage difference between the number of turkeys raised in Minnesota and North Carolina based on North Carolina's number of turkeys?
- A. 1%
  - B. 2%
  - C. 50%
  - D. 100%

Use the information below to answer question 23.

1. Ana  
2. Ed  
3. Jan

1. Jan  
2. Ana  
3. Ed

1. Jan  
2. Ed  
3. Ana

1. Jan  
2. Ana  
3. Ed

1. Ana  
2. Ed  
3. Jan

1. Ana  
2. Ed  
3. Jan

1. Ana  
2. Ed  
3. Jan

1. Ed  
2. Jan  
3. Ana

1. Jan  
2. Ed  
3. Ana

1. Ed  
2. Ana  
3. Jan

23. Ten of the eleven ballots collected for student council representative from Mrs. Rodriguez's homeroom are shown. Using a run-off method of voting, which of the following ballots would need to be cast as the eleventh ballot in order for Jan to win?

A. 

1. Ed
2. Ana
3. Jan

B. 

1. Ed
2. Jan
3. Ana

C. 

1. Ana
2. Ed
3. Jan

D. 

1. Ana
2. Jan
3. Ed

24. There are four performers in a school talent show. In how many ways can the performers be arranged by different order of appearance?

- A. 12
- B. 16
- C. 24
- D. 256

25. In the high school parking lot 16% of the vehicles are trucks and 8% of the vehicles are painted yellow. If these characteristics are mutually exclusive, what is the probability that a vehicle in the high-school parking lot will be a yellow truck?

- A. 0%
- B. 1%
- C. 2%
- D. 8%

Please fill in the grid with your answer to question 26 on page 6 of your answer book.

26. What is the probability that a family with 4 children will have exactly 2 girls and 2 boys?

**There is no test material on this page.**

Put sticker  
here

**This is the end of Segment 2.**

Check your work, then  
**SEAL** Segment 2.





## Segment 3

Your teacher will tell you when to begin this segment.

You **MAY** use a calculator for this segment.



Put sticker  
here

## Mathematics Test — Segment 3

Use the table below to answer question 27.

**Rolling a Number Cube**

Cube Face	Frequency
1	4
2	3
3	1
4	3
5	5
6	2

27. Emma rolls a fair, 6-sided number cube, numbered 1 to 6, 18 times as shown in the frequency table. She rolls the number cube 72 more times. What is the range representing the number of times Emma will most likely roll a 3 in her 90 rolls?
- A. From 0 to 10
  - B. From 11 to 20
  - C. From 21 to 30
  - D. From 31 to 40

28. A store has 25 VCRs in stock, but 2 of these are defective. What is the probability that the second person to buy a VCR gets a defective one, given that the first customer's was **not** defective? Round your answer to the nearest thousandth.

- A. 0.003
- B. 0.042
- C. 0.080
- D. 0.083

29. A survey shows that 55% of the registered voters in Plainville voted on the school budget proposal. Of those who voted, 62% voted to pass the school budget. What is the probability that a registered voter chosen at random voted to pass the school budget?

- A. 0.171
- B. 0.209
- C. 0.279
- D. 0.341

30. The height of a right cylindrical can of peas is greater than the diameter of the base of the can. The can is sliced into two equal parts through its bases. Which figure best describes the cross section of the cylinder?

- A. Circle
- B. Triangle
- C. Rectangle
- D. Semicircle

Use the diagram below to answer question 31.

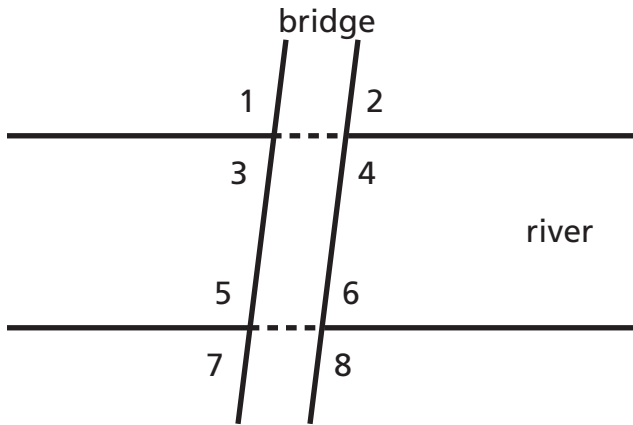

31. An engineer models a bridge crossing a river using two parallel lines to represent the riverbanks and two parallel lines to represent the bridge in the aerial view shown. The bridge is not perpendicular to the riverbanks. Which of the following statements about the angles formed between the bridge and the riverbanks must be true?

- A.  $\angle 5 \cong \angle 3$
- B.  $\angle 1 \cong \angle 2$
- C.  $\angle 2 \cong \angle 8$
- D.  $\angle 1 \cong \angle 8$

Use the diagram below to answer question 32.

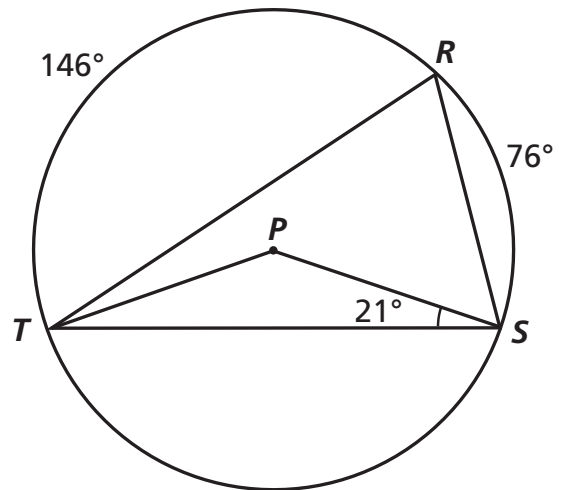

32. Jeremy is the set designer for the school play. The center of the circular stage he is designing is at point  $P$ . Walls of the set are represented by  $\overline{PS}$ ,  $\overline{PT}$ ,  $\overline{RS}$ , and  $\overline{RT}$ . Using the angle and arc measurements in the diagram, what is the measure, in degrees, of  $\angle RTP$ ?

- A.  $17^\circ$
- B.  $19^\circ$
- C.  $21^\circ$
- D.  $38^\circ$

Use the figure below to answer question 33.

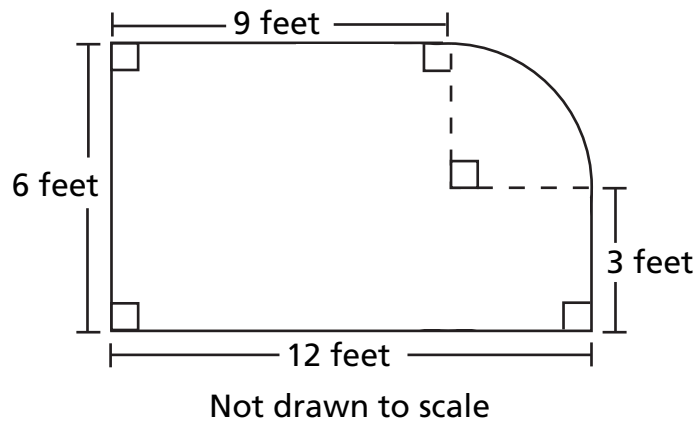

33. Find the area of the figure. (Use 3.14 for  $\pi$ .)

- A. 67.71 square feet
- B. 70.07 square feet
- C. 72 square feet
- D. 91.26 square feet

34. Elena inherited 3 small spherical gold beads from her grandmother. They had radii of 2 mm, 3 mm, and 4 mm. She wanted to have them melted and recast to form one larger sphere. Its radius would be closest to

- A. 3 mm.
- B. 5 mm.
- C. 6 mm.
- D. 9 mm.

Use the diagram below to answer question 35.

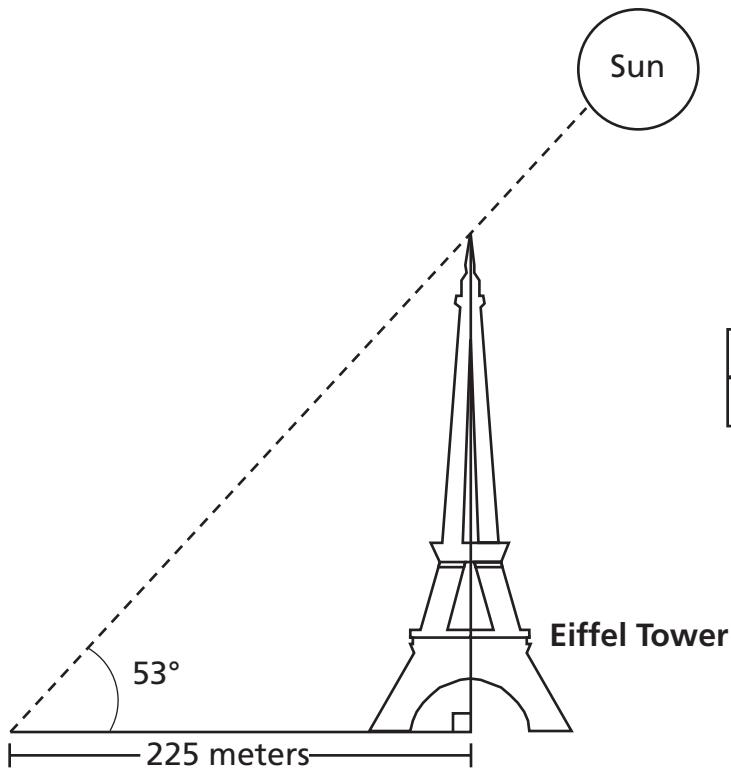

	sin	cos	tan
$53^\circ$	0.7986	0.6018	1.3270

35. At a certain time of day, the length of the shadow of the Eiffel Tower to the center of its base was 225 meters when the sun's angle of elevation was 53 degrees. What is the approximate height of the Eiffel Tower?

- A. 135 meters
- B. 180 meters
- C. 300 meters
- D. 375 meters

3

Use the graph below to answer question 36.

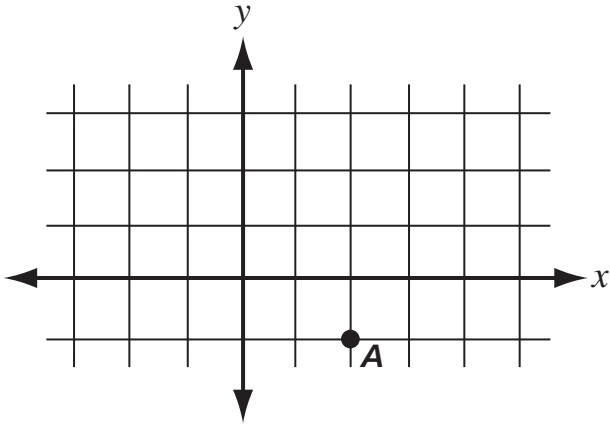

36. The point  $A$  is translated to the left 4 units and up 3 units. How far is image  $A$  from the original point  $A$ ?

- A. 3 units
- B. 4 units
- C. 5 units
- D. 7 units

37. A small plane needs to refuel approximately halfway to its destination. It takes off from its base located at  $(7, -2)$  on a coordinate grid and its destination is located at  $(-3, 6)$ . Which of the following locations is closest to halfway?

- A.  $(2.2, 2)$
- B.  $(2.5, 1.5)$
- C.  $(4, 1.5)$
- D.  $(5, -4.5)$

38. A commercial artist has a sketch of a rectangular logo that is 7 inches high. She needs to proportionally reproduce the logo on a sign that is 8 feet high. The sketch of the logo contains a letter M that is 5 inches tall. To the nearest tenth of a foot, how tall will the letter M be on the larger sign?

- A. 4.4 feet
- B. 5.7 feet
- C. 6.0 feet
- D. 11.2 feet

39. A family is carpeting two rectangular rooms. They have chosen carpeting that costs the same amount per square yard for each room. A 12-foot by 15-foot carpet for the bedroom costs \$600. If the dimensions of the living room are 20 feet by 18 feet, what will it cost to carpet the living room?

- A. \$624
- B. \$720
- C. \$1,000
- D. \$1,200



**There is no test material on this page.**

**This is the end of Segment 3.**

Check your work, then  
**SEAL** Segment 3.

Put sticker  
here



Grade 11 Mathematics Answer Book
Minnesota Comprehensive Assessments-Series II
Spring 2011

BIRTH DATE
MONTH DAY YEAR
JAN FEB MAR APR MAY JUN JUL AUG SEP OCT NOV DEC
0 0 19 0 0
1 1 20 7 1
2 2 8 2
3 3 9 3
4 4
5 5
6 6
7 7
8 8
9 9

GENDER
MALE
FEMALE

Math Form #
1 2 3

Foreign Exchange
Home Schooled
New-to-Country
Significant Gap in Enrollment

STUDENT'S LAST NAME STUDENT'S FIRST NAME M
A A
B B
C C
D D
E E
F F
G G
H H
I I
J J
K K
L L
M M
N N
O O
P P
Q Q
R R
S S
T T
U U
V V
W W
X X
Y Y
Z Z
' '
- -

MATHEMATICS ITEM SAMPLER
Student Information page reflects the actual test. This Item Sampler may be reproduced.

SCHOOL USE ONLY
District Name:
School Name:
MARSS LOC DIST DATA
MARSS NUMBER
TEST CODES
ACCOMMODATIONS

ALIGN TOP OF LABEL HERE

## Mathematics Test — Segment 1

1. (A) (B) (C) (D)

2.

-	/	/	/	
•	•	•	•	•
0	0	0	0	0
1	1	1	1	1
2	2	2	2	2
3	3	3	3	3
4	4	4	4	4
5	5	5	5	5
6	6	6	6	6
7	7	7	7	7
8	8	8	8	8
9	9	9	9	9

3. (A) (B) (C) (D)

4. (A) (B) (C) (D)  
 5. (A) (B) (C) (D)  
 6. (A) (B) (C) (D)

7. (A) (B) (C) (D)  
 8. (A) (B) (C) (D)  
 9. (A) (B) (C) (D)

10. (A) (B) (C) (D)  
 11. (A) (B) (C) (D)  
 12. (A) (B) (C) (D)

## Mathematics Test — Segment 2

13. (A) (B) (C) (D)  
 14. (A) (B) (C) (D)  
 15. (A) (B) (C) (D)  
 16. (A) (B) (C) (D)  
 17. (A) (B) (C) (D)  
 18. (A) (B) (C) (D)  
 19. (A) (B) (C) (D)

20. (A) (B) (C) (D)  
 21. (A) (B) (C) (D)  
 22. (A) (B) (C) (D)  
 23. (A) (B) (C) (D)  
 24. (A) (B) (C) (D)  
 25. (A) (B) (C) (D)

26.

-	/	/	/	
•	•	•	•	•
0	0	0	0	0
1	1	1	1	1
2	2	2	2	2
3	3	3	3	3
4	4	4	4	4
5	5	5	5	5
6	6	6	6	6
7	7	7	7	7
8	8	8	8	8
9	9	9	9	9

## Mathematics Test — Segment 3

27. (A) (B) (C) (D)  
 28. (A) (B) (C) (D)  
 29. (A) (B) (C) (D)  
 30. (A) (B) (C) (D)  
 31. (A) (B) (C) (D)

32. (A) (B) (C) (D)  
 33. (A) (B) (C) (D)  
 34. (A) (B) (C) (D)  
 35. (A) (B) (C) (D)

36. (A) (B) (C) (D)  
 37. (A) (B) (C) (D)  
 38. (A) (B) (C) (D)  
 39. (A) (B) (C) (D)

# Grade 11 Teacher's Guide



## MCA-II Item Sampler Teacher's Guide

[mde.testing@state.mn.us](mailto:mde.testing@state.mn.us)

### An Introduction to the MCA-IIs

The Minnesota Comprehensive Assessments are reading, mathematics and science tests that help schools and districts measure student progress toward the state's academic Standards. In 2006, the reading and mathematics tests were aligned to the 2003 Minnesota Academic Standards and were named the Minnesota Comprehensive Assessment-Series II (MCS-II). The Science MCA-IIs became operational in 2008 and are aligned to the 2003 Minnesota Academic Standards. The grades 3–8 mathematics assessments will be operational in 2011 as the Minnesota Comprehensive Assessments-Series III (MCA-III) and are aligned to the 2007 Minnesota Academic Standards.

### The Purpose of the MCA-II Item Samplers

An item sampler is not a complete test. It contains a smaller number of the items that students will see on a full-length test in the spring. The MCA-II Item Samplers were developed to familiarize students and teachers with the format of the MCA-IIs and the kinds of items that will appear on them.

This MCA-II Item Sampler is not a real test. It should not be used to predict how well students will do on the tests. However, students may feel more comfortable with the tests if they have reviewed the Item Samplers prior to the test.

### How the MCA-II Item Samplers Were Created

The Item Samplers mirror the format of the MCA-IIs. The student directions, segment layouts, and answer sheet each reflect the way the test will look in the spring, except that the Item Sampler is shorter than the actual test. As with all MCA-IIs, the reading passages and the math and reading questions have been thoroughly reviewed by Minnesota teachers prior to testing. Minnesota students have answered these questions on previous tests.

The distribution of question types and their aligned content selected for the Item Sampler generally reflects a range of items from each strand in the Minnesota Academic Standards. Whenever possible, the Item Samplers have the following designs:

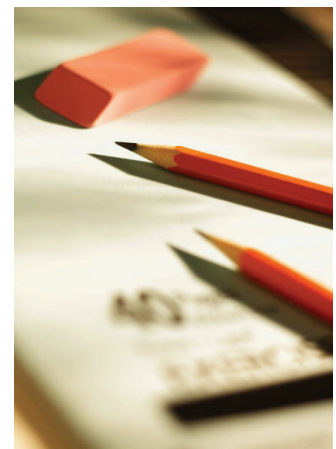

# Grade 11 Teacher's Guide

## Math:

- Three segments
  - All Grade 11 segments allow for the use of a calculator.
  - The actual MCA-II has four segments.
- Approximately thirty-seven multiple-choice items
- Two gridded-response items
- Formula sheet

## Reading:

- Three segments
  - The actual MCA-II has four segments.
- Four passages
  - Fiction, nonfiction and poetry will be used if available and aligned to the test specifications for that grade level.
- Eight to ten multiple-choice items per passage
- Appropriate Degree of Reading Power (DRP) and word length of passages for the test specifications of the grade

## The Contents of This Teacher's Guide

The Answer Key identifies the answers and solutions to the questions. It also identifies the strand/sub-strand/benchmark from the Minnesota Academic Standards for the question.

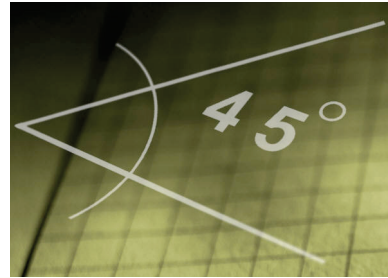

## State Standards & Test Specifications

The Item Samplers are primarily intended to familiarize teachers and students with the **format** of the MCA-IIs. The best preparation for the **content** of the MCA-IIs is done as a part of your curriculum planning. When doing that, reference the Minnesota Academic Standards and the test specifications for the MCA-IIs. For further questions about the MCA-IIs, email us at [mde.testing@state.mn.us](mailto:mde.testing@state.mn.us).

# Grade 11 Teacher's Guide

## MCA-II Item Sampler Answer Key Grade 11 Math

Item #	Correct Answer	Item Type	Calculator Designation	Strand	Sub-Strand	Benchmark	Cognitive Level
1	A	MC	CL	III	A	1	B
2	65	GR	CL	III	A	1	B
3	C	MC	CL	III	A	2	B
				I	A	6	
4	D	MC	CL	III	A	4	B
				I	A	1	
5	B	MC	CL	III	A	5	A
6	C	MC	CL	III	B	2	A
7	B	MC	CL	III	B	3	B
8	A	MC	CL	III	B	4	A
9	A	MC	CL	III	B	5	B
10	D	MC	CL	III	B	5	B
				I	A	1	
11	A	MC	CL	III	B	6	A
12	A	MC	CL	III	B	7	B
13	D	MC	CL	III	B	8	B
14	D	MC	CL	III	B	9	A
15	C	MC	CL	III	B	10	B
16	A	MC	CL	III	B	11	A
17	D	MC	CL	III	B	12	A
18	D	MC	CL	IV	A	2	B
19	C	MC	CL	IV	A	2	B
20	C	MC	CL	IV	A	3	A
21	C	MC	CL	IV	A	5	B
22	B	MC	CL	IV	A	6	B
				I	A	1	
23	B	MC	CL	IV	A	7	B
24	C	MC	CL	IV	B	1	A
25	A	MC	CL	IV	B	2	A
				I	A	6	
26	0.375	GR	CL	IV	B	3	B
				I	A	3	
27	B	MC	CL	IV	B	4	A
28	D	MC	CL	IV	B	6	B
29	D	MC	CL	IV	B	6	A
30	C	MC	CL	V	A	1	A
31	D	MC	CL	V	B	1	A
32	A	MC	CL	V	B	2	B
33	B	MC	CL	V	B	3	B
				I	A	3	
34	B	MC	CL	V	B	3	C
				I	A	4	
35	C	MC	CL	V	B	4	B
36	C	MC	CL	V	B	5	B
37	A	MC	CL	V	B	5	A
38	B	MC	CL	V	B	6	B
39	D	MC	CL	V	C		B

# Grade 11 Teacher’s Guide

## Legend:

**Item #** — The number of the question in the Item Sampler.

**Correct Answer** — Answers to multiple-choice questions are listed. Answers to gridded-response items are listed in the Annotation pages that follow this answer key.

**Item Type** — Multiple Choice (**MC**), or Gridded Response (**GR**)

**Calculator Designation** — **CL** indicates that a calculator can be used on this item. **NC** indicates a student cannot use a calculator.

**Strand** — In mathematics, the MCA-II measures five strands:

- I: Mathematical Reasoning
- II: Number Sense, Computation and Operations
- III: Patterns, Functions and Algebra
- IV: Data Analysis, Statistics and Probability
- V: Spatial Sense, Geometry and Measurement

**Sub-strand** — A segment of a strand. The sub-strand for each strand in mathematics are the following:

Strands	Sub-strands		
	A	B	C
I. Mathematical Reasoning			
II. Number Sense, Computation and Operations	Number Sense	Computation and Operation	
III. Patterns, Functions and Algebra	Patterns and Functions	Algebra (Algebraic Thinking)	
IV. Data Analysis, Statistics and Probability	Data and Statistics	Probability	
V. Spatial Sense, Geometry and Measurement	Spatial Sense	Geometry	Measurement

**Benchmark** — A segment of a sub-strand. See the test specifications for an explanation of a specific number.

**Cognitive Level** — A classification of the complexity of an item type based on Bloom’s Taxonomy. See the test specifications for an explanation of cognitive levels. The cognitive levels for items on the MCA-IIs are the following:

- Level A: Knowledge
- Level B: Understanding
- Level C: Application, Analysis, Synthesis and Evaluation



# MCA-II Item Sampler

## Sample Gridded Responses

### Grade 11 Mathematics

Question 2 from page 6

2.

65					
-	/	/	/		
•	•	•	•	•	•
0	0	0	0	0	0
1	1	1	1	1	1
2	2	2	2	2	2
3	3	3	3	3	3
4	4	4	4	4	4
5	5	5	5		5
6	6	6		6	6
7	7	7	7	7	7
8	8	8	8	8	8
9	9	9	9	9	9

2.

65					
-	/	/	/		
•	•	•	•	•	•
0	0	0	0	0	0
1	1	1	1	1	1
2	2	2	2	2	2
3	3	3	3	3	3
4	4	4	4	4	4
5		5	5	5	5
	6	6	6	6	6
7	7	7	7	7	7
8	8	8	8	8	8
9	9	9	9	9	9

2.

65					
-	/	/	/		
•	•	•	•	•	•
0	0	0	0	0	0
1	1	1	1	1	1
2	2	2	2	2	2
3	3	3	3	3	3
4	4	4	4	4	4
5	5		5	5	5
6		6	6	6	6
7	7	7	7	7	7
8	8	8	8	8	8
9	9	9	9	9	9

2.

65					
-	/	/	/		
•	•	•	•	•	•
0	0	0	0	0	0
1	1	1	1	1	1
2	2	2	2	2	2
3	3	3	3	3	3
4	4	4	4	4	4
5	5	5		5	5
6	6		6	6	6
7	7	7	7	7	7
8	8	8	8	8	8
9	9	9	9	9	9

**Note:** the sample grids above demonstrate multiple ways to correctly solve the same problem.

# MCA-II Item Sampler

## Sample Gridded Responses

### Grade 11 Mathematics

Question 26 from page 24

26.

0.	3	7	5	
-	/	/	/	
+	-	+	-	+
0	0	0	0	0
1	1	1	1	1
2	2	2	2	2
3	3	3	3	3
4	4	4	4	4
5	5	5	5	5
6	6	6	6	6
7	7	7	7	7
8	8	8	8	8
9	9	9	9	9

26.

.	3	7	5	
-	/	/	/	
+	-	+	-	+
0	0	0	0	0
1	1	1	1	1
2	2	2	2	2
3	3	3	3	3
4	4	4	4	4
5	5	5	5	5
6	6	6	6	6
7	7	7	7	7
8	8	8	8	8
9	9	9	9	9

26.

3	/	8		
-	/	/	/	
+	-	+	-	+
0	0	0	0	0
1	1	1	1	1
2	2	2	2	2
3	3	3	3	3
4	4	4	4	4
5	5	5	5	5
6	6	6	6	6
7	7	7	7	7
8	8	8	8	8
9	9	9	9	9

26.

3	/	8		
-	/	/	/	
+	-	+	-	+
0	0	0	0	0
1	1	1	1	1
2	2	2	2	2
3	3	3	3	3
4	4	4	4	4
5	5	5	5	5
6	6	6	6	6
7	7	7	7	7
8	8	8	8	8
9	9	9	9	9

**Note:** the sample grids above demonstrate multiple ways to correctly solve the same problem.

